

**TAKING A
L E A P
FORWARD**

**4-Wheel
M G B**

200

FLAT LID



MGB1100

Waste Containers (4-Wheel Flat Lid)

Latest technology modern design

New Features

STRONGER IN USE

- Stronger, redesigned body
- Reinforced base, wheel housing and comb construction
- Flexible lid to resist maximum strain
- Less wear and tear - increasing expected lifetime
- Improved emptying characteristics thanks to redesigned and steel reinforced trunnions
- Reinforced and protected hinge arrangement

EASIER TO MAINTAIN

- Universal, easily interchangeable parts - requiring fewer spare parts in stock
- Smooth surface in the base area - making for easier cleaning
- Lid less susceptible to wind and rain
- Four safe and ergonomic handles - exchangeable
- Improved and repositioned drain plug
- Lid side lip for automatic lid centring

READY FOR THE FUTURE

- Improved health and safety characteristics
- Ready for use with recycling apertures and various options
- EN 840 (1997) certified, already based on expected EN 840 - 2004 revision
- Optimum space for customised markings
- A solid backup arrangement and a backup set of moulds provide supply security

DETAILS

Nominal volume	1100 litres
Dead weight/useful load	50 kg / 440 kg
Wheels	4, rubber, (2 with brakes)
Material	HDPE, UV resistant
Standards	EN 840 (1997) & revision 2004
Colours	grey, blue, green, brown - other colours on request

DIMENSIONS

A - Overall height	1354 mm
B1 - Width	1373 mm
B2 - Width	1257 mm
C1 - Overall depth	1073 mm
C2 - Depth	580 mm
D - Upper edge comb	1206 mm
E - Wheel diameter	200 mm

ADVANTAGES OF THE NEW DESIGN

We have not only redesigned our 1100 sl series, we have almost reinvented it. More than a variation, the flat lid model is a dedicated development, integrating numerous improvements to create a smoother design. This means lower operational costs, safer operation and easier handling. The next generation 1100 sl series offers you a product of the future.

Flat Lid

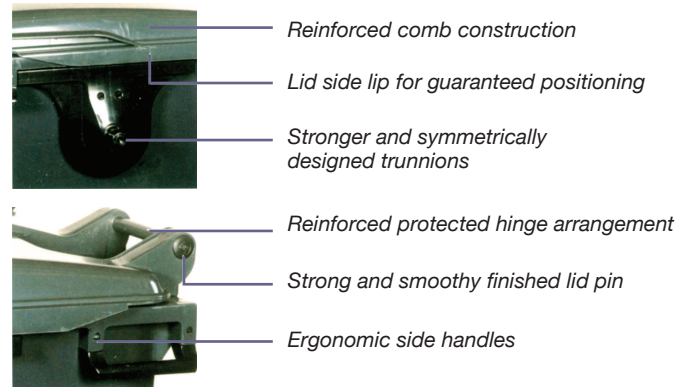

Body

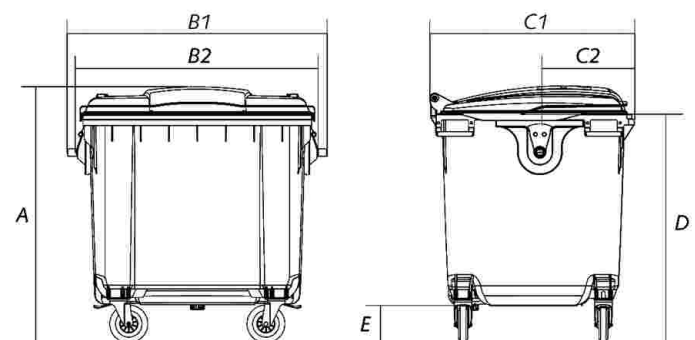
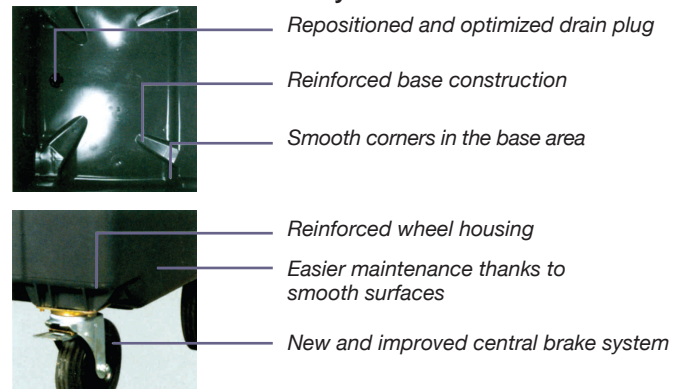

Distributor:



www.ottoasiapac.com